

### FEATURES

- 1. Slim and compact size**  
20% smaller (width and height) than existing model\* (with the condition of screw terminal socket for DIN rail)  
\*Compared with our HC/HJ relay.
- 2. High-capacity and high reliability**  
Max. switching current:  
16 A (for 1 Form C type at AC load)  
Uses gold-flashed contacts for highly reliable contact (for 2 Form C type).
- 3. Environmentally friendly**  
Cadmium-free contacts and lead-free solder are used.
- 4. Slim screw terminal socket and PC board terminal socket**  
Utilizes relay-securing hook for easy relay removal.  
One-touch relay removal possible.  
Terminal sockets with finger protect function available.

### 5. Full lineup

We added a direct mount type that can be built into devices.

### TYPICAL APPLICATIONS

- Control panels
- Power supply units
- Molding machines
- Machine tools
- Welding equipment
- Agricultural equipment
- Office equipment
- Vending machines
- Communications equipment
- Amusement machines, etc.

RoHS Directive compatibility information  
<http://www.nais-e.com/>

## SPECIFICATIONS (Plug-in Standard type and Direct mount type)

### Contacts

		1 Form C	2 Form C	1 Form A (Direct mount type)
Contact arrangement				
Initial contact resistance, max. (By voltage drop 6 V DC 1 A)		100mΩ	50mΩ	100mΩ
Contact material		AgSnO <sub>2</sub> type	Au-flashed AgNi type	AgSnO <sub>2</sub> type alloy
Rating (resistive load)	Nominal switching capacity	10A 250V AC, 10A 30V DC	5A 250V AC, 5A 30V DC	16A 250V AC, 16A 30V DC
	Max. switching power	4,000 VA, 300W	1,250 VA, 150W	4,000 VA, 480W
	Max. switching voltage	250V AC, 30V DC		
	Max. switching current	16 A (at AC load), 10 A (at DC load)	5 A	16 A
	Min. switching capability (Reference value) <sup>9</sup>	5V 100mA DC	1V 1mA DC	5V 100mA DC
Expected life (min. operations)	Mechanical (at 300 cpm)	AC: 10 <sup>7</sup> DC: 2×10 <sup>7</sup>		
	Electrical (at rated load)	10 <sup>5</sup> (at 20 cpm)		10 <sup>5</sup> (at 10 cpm)

### Coil

Nominal operating power	0.53W 0.9VA
-------------------------	-------------

### Remarks

- \* Specifications will vary with foreign standards certification ratings.
- <sup>1</sup> Measurement at same location as "Initial breakdown voltage" section
- <sup>2</sup> Detection current: 10mA
- <sup>3</sup> Excluding contact bounce time
- <sup>4</sup> For the AC coil types, the operate/release time will differ depending on the phase.
- <sup>5</sup> Half-wave pulse of sine wave: 11ms; detection time: 10μs
- <sup>6</sup> Half-wave pulse of sine wave: 6ms
- <sup>7</sup> Detection time: 10μs
- <sup>8</sup> Refer to 4. Conditions for operation, transport and storage mentioned in NOTES
- <sup>9</sup> This value can change due to the switching frequency, environmental conditions and desired reliability level, therefore it is recommended to check this with the actual load.

### Characteristics

		1 Form C and 2 Form C types: 20 cpm (at max. rating) 1 Form A type: 10 cpm (at max. rating)
Max. operating speed		
Initial insulation resistance <sup>1</sup>		Min. 1,000 MΩ at 500 V DC
Initial breakdown voltage <sup>2</sup>	Between open contacts	1,000 Vrms for 1 min.
	Between contact sets	3,000 Vrms for 1 min. (2 Form C type only)
	Between contact and coil	5,000 Vrms for 1 min.
Operate time <sup>3</sup> (at nominal voltage) (at 20°C)		Max. 15 ms <sup>4</sup>
Release time <sup>3</sup> (at nominal voltage) (at 20°C)		Max. 5 ms (without diode) <sup>4</sup> Max. 20 ms (with diode) <sup>4</sup>
Temperature rise, max. (at 70°C) (at nominal voltage)		60°C
Shock resistance	Functional <sup>5</sup>	Min. 100 m/s <sup>2</sup> {10 G}
	Destructive <sup>6</sup>	Min. 1,000 m/s <sup>2</sup> {100 G}
Vibration resistance	Functional <sup>7</sup>	10 to 55 Hz at double amplitude of 1.5 mm
	Destructive	10 to 55 Hz at double amplitude of 1.5 mm
Conditions for operation, transport and storage <sup>8</sup> (Not freezing and condensing at low temperature)	Ambient temp.	-40°C to +70°C -40°F to +158°F
	Humidity	5 to 85% R.H.
Unit weight		For 1 Form C and 1 Form A types: approx. 19 g .67 oz For 2 Form C type: approx. 17 g .60 oz

# HN (AHN1, 2, 3)

## ORDERING INFORMATION

Ex. AHN



Contact arrangement	Terminal arrangement	Type classification	Coil voltage
1: 1 Form C 2: 2 Form C 3: 1 Form A (Direct mount type only)	1: AC plug-in type 2: DC plug-in type 5: AC direct mount type (TM type) 6: DC direct mount type (TM type)	0: Standard 1: With LED indication 2: With diode 3: With diode and LED indication	05: 5 V, 06: 6 V, 12: 12 V, 24: 24 V, 48: 48 V X0: 100/110 V AC, 100 V DC X1: 110/120 V AC, 110 V DC Y0: 200/220 V AC, Y2: 220/240 V AC

Note: Products conform to UL/C-UL and VDE, as standard. (VDE under application for direct mount type.)

## TYPES

### 1. Plug-in type

Coil voltage	1 Form C	2 Form C
	Part No.	Part No.
5V DC	AHN12005	AHN22005
6V DC	AHN12006	AHN22006
12V DC	AHN12012	AHN22012
24V DC	AHN12024	AHN22024
48V DC	AHN12048	AHN22048
100V DC	AHN120X0	AHN220X0
110V DC	AHN120X1	AHN220X1
12V AC	AHN11012	AHN21012
24V AC	AHN11024	AHN21024
100/110V AC	AHN110X0	AHN210X0
110/120V AC	AHN110X1	AHN210X1
200/220V AC	AHN110Y0	AHN210Y0
220/240V AC	AHN110Y2	AHN210Y2

Note: Packing quantity; Inner carton: 50 pcs, Outer carton: 500 pcs.

### 2. Plug-in with LED indication type

Coil voltage	1 Form C	2 Form C
	Part No.	Part No.
5V DC	AHN12105	AHN22105
6V DC	AHN12106	AHN22106
12V DC	AHN12112	AHN22112
24V DC	AHN12124	AHN22124
48V DC	AHN12148	AHN22148
100V DC	AHN121X0	AHN221X0
110V DC	AHN121X1	AHN221X1
12V AC	AHN11112	AHN21112
24V AC	AHN11124	AHN21124
100/110V AC	AHN111X0	AHN211X0
110/120V AC	AHN111X1	AHN211X1
200/220V AC	AHN111Y0	AHN211Y0
220/240V AC	AHN111Y2	AHN211Y2

Note: Packing quantity; Inner carton: 50 pcs, Outer carton: 500 pcs.

### 3. Plug-in with diode type

Coil voltage	1 Form C	2 Form C
	Part No.	Part No.
5V DC	AHN12205	AHN22205
6V DC	AHN12206	AHN22206
12V DC	AHN12212	AHN22212
24V DC	AHN12224	AHN22224
48V DC	AHN12248	AHN22248
100V DC	AHN122X0	AHN222X0
110V DC	AHN122X1	AHN222X1

Note: Packing quantity; Inner carton: 50 pcs, Outer carton: 500 pcs.

### 4. Plug-in with diode and LED indication type

Coil voltage	1 Form C	2 Form C
	Part No.	Part No.
5V DC	AHN12305	AHN22305
6V DC	AHN12306	AHN22306
12V DC	AHN12312	AHN22312
24V DC	AHN12324	AHN22324
48V DC	AHN12348	AHN22348
100V DC	AHN123X0	AHN223X0
110V DC	AHN123X1	AHN223X1

Note: Packing quantity; Inner carton: 50 pcs, Outer carton: 500 pcs.

### 5. Direct mount type (TM type)

Coil voltage	1 Form A
	Part No.
5V DC	AHN36005
6V DC	AHN36006
12V DC	AHN36012
24V DC	AHN36024
48V DC	AHN36048
100V DC	AHN360X0
110V DC	AHN360X1
12V AC	AHN35012
24V AC	AHN35024
100/110V AC	AHN350X0
110/120V AC	AHN350X1
200/220V AC	AHN350Y0
220/240V AC	AHN350Y2

Note: Packing quantity; Inner carton: 50 pcs, Outer carton: 500 pcs.

## 6. Accessories

Type	No. of channels	Item	Part No.
Screw terminal socket	1 channel	HN1 screw terminal socket	AHNA11
		HN1 screw terminal socket (Finger protect type)	AHNA11P
	2 channels	HN2 screw terminal socket	AHNA21
		HN2 screw terminal socket (Finger protect type)	AHNA21P
PC board terminal socket	1 channel	HN1 PC board terminal socket	AHNA13
	2 channels	HN2 PC board terminal socket	AHNA23

Notes: 1. Packing quantity: 10pcs. (Inner carton), 100pcs. (Outer carton)  
 2. Products conform to UL/C-UL, as standard.

## • Outline of performance

Item		Performance					
Type		HN1 screw terminal socket	HN1 screw terminal socket (Finger protect type)	HN1 PC board terminal socket	HN2 screw terminal socket	HN2 screw terminal socket (Finger protect type)	HN2 PC board terminal socket
Contact arrangement		1 Form C			2 Form C		
Max. continuous current (Ambient temperature: -40 to +70°C -40 to +158°F)		16A*	10A	10A	5A	5A	5A
Initial breakdown voltage	Between open contacts	1, 000 Vrms for 1 min. (Detection current: 10mA)					
	Between contact sets	—			3, 000 Vrms for 1 min. (Detection current: 10mA)		
	Between contact and coil	5, 000 Vrms for 1 min. (Detection current: 10mA)					
Initial insulation resistance		1, 000 MΩ between each terminal (500V DC)					

\* When using with current of 16 A (for HN1 screw terminal socket), the maximum ambient temperature is 50°C.

When using between 50°C and 70°C, please reduce by 0.1 A/°C.

Notes: 1. In order to prevent breakage and disfiguring, the screw tightening torque for the terminal socket should be within the range of 0.5 to 0.8 N•m.

2. When attaching the terminal socket directly to a chassis, please use the metric coarse thread screw.

- AHNA11 and AHNA21: M3 × 16, - AHNA11P and AHNA21P: M3 × 30

## COIL DATA (at 20°C 68°F)

### DC coils

Coil voltage V DC	Pick-up voltage, V DC (max.) (Initial)	Drop-out voltage, V DC (min.) (Initial)	Nominal coil current, mA (±20%)	Coil resistance, Ω (±10%)	Nominal operating power, W	Max. allowable voltage, V DC
5	3.5	0.5	106.4	47	0.53	8.5
6	4.2	0.6	88.2	68		10.2
12	8.4	1.2	44.4	270		20.4
24	16.8	2.4	22.0	1,090		40.8
48	33.6	4.8	11.0	4,350		81.6
100	70	10	5.3	18,870		170
110	77	11	4.8	22,830		187

### AC coils (50/60Hz)

Coil voltage V AC	Pick-up voltage, V AC (max.) (Initial)	Drop-out voltage, V AC (min.) (Initial)	Nominal coil current, mA (±20%)		Nominal operating power, VA		Max. allowable voltage, V AC
			50Hz	60Hz	50Hz	60Hz	
12	9.6	3.6	93	75	Approx. 1.1 to 1.4	Approx. 0.9 to 1.2	16.8
24	19.2	7.2	46.5	37.5			33.6
100/110	80/88	30/33	11.0/13.0	9.0/10.6			140/154
110/120	88/96	33/36	10.0/11.8	8.2/9.7			154/168
200/220	160/176	60/66	5.5/6.5	4.5/5.3			280/308
220/240	176/192	66/72	5.0/5.9	4.1/4.8			308/336

# HN (AHN1, 2, 3)

## DIMENSIONS

mm inch

### 1. Plug-in type 1 Form C

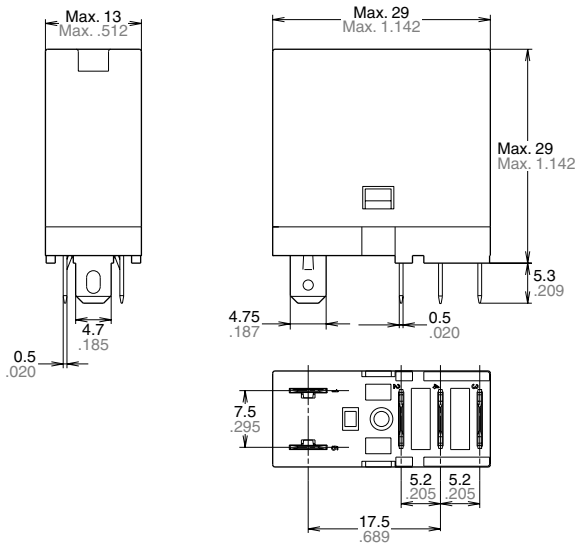

Dimension :	Tolerance
Max. 1mm .039 inch:	$\pm 0.1 \pm 0.004$
1 to 3mm .039 to .118 inch:	$\pm 0.2 \pm 0.008$
Min. 3mm .118 inch:	$\pm 0.3 \pm 0.012$

#### Schematic (Bottom view)

##### Standard type

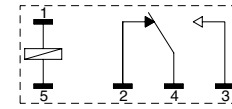

##### With LED AC type

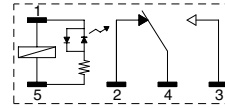

##### With LED DC type

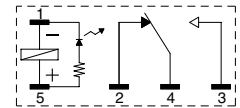

##### With Diode type

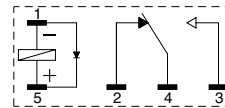

##### With Diode and LED type

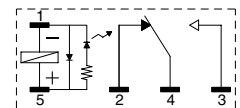

### 2. Plug-in type 2 Form C

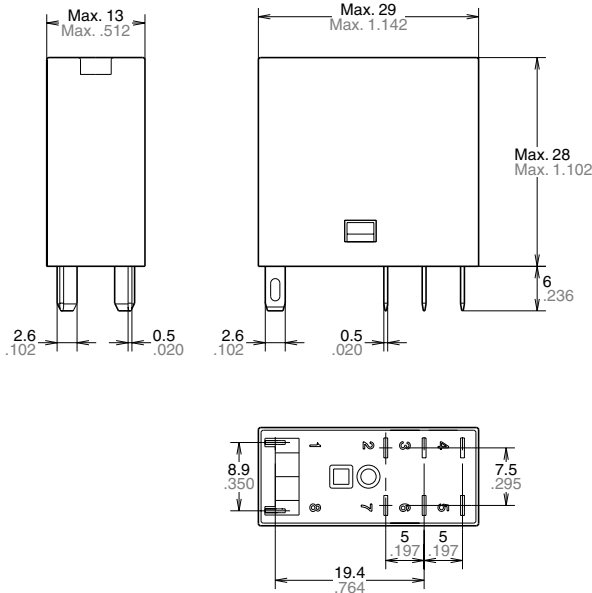

Dimension :	Tolerance
Max. 1mm .039 inch:	$\pm 0.1 \pm 0.004$
1 to 3mm .039 to .118 inch:	$\pm 0.2 \pm 0.008$
Min. 3mm .118 inch:	$\pm 0.3 \pm 0.012$

#### Schematic (Bottom view)

##### Standard type

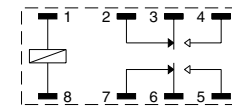

##### With LED AC type

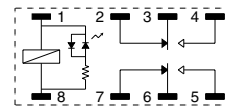

##### With LED DC type

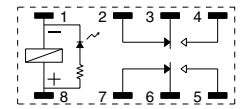

##### With Diode type

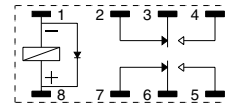

##### With Diode and LED type

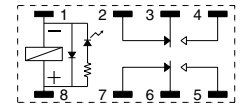

## 3. Direct mount type 1 Form A

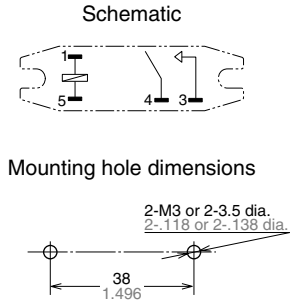
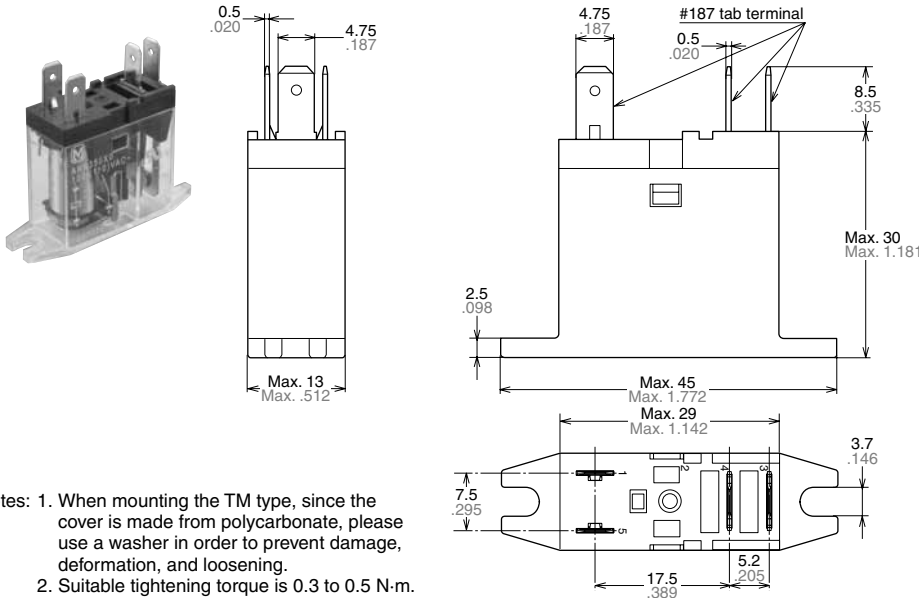

Notes: 1. When mounting the TM type, since the cover is made from polycarbonate, please use a washer in order to prevent damage, deformation, and loosening.  
2. Suitable tightening torque is 0.3 to 0.5 N-m.

Dimension :	Tolerance
Max. 1mm .039 inch:	±0.1 ±.004
1 to 3mm .039 to .118 inch:	±0.2 ±.008
Min. 3mm .118 inch:	±0.3 ±.012

## 4. HN1 Screw terminal socket

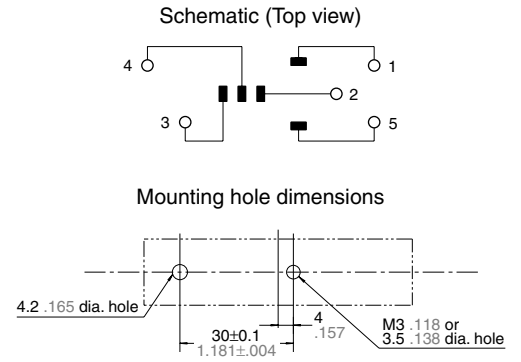
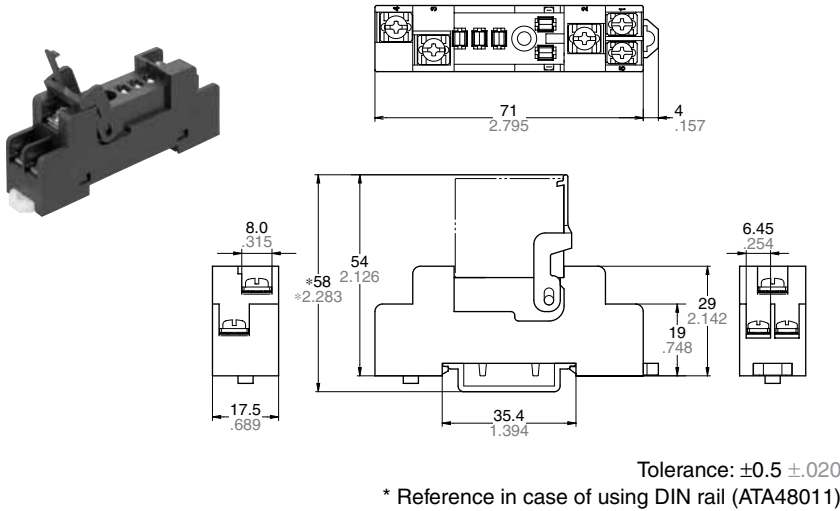

## 5. HN1 Screw terminal socket (Finger protect type)

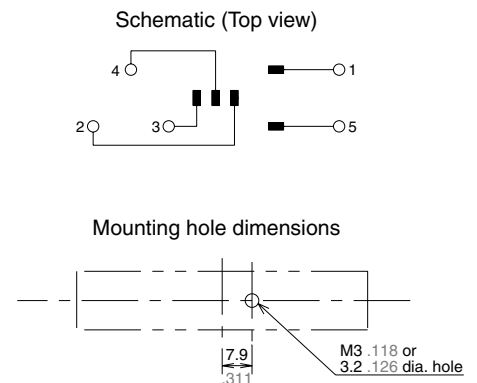
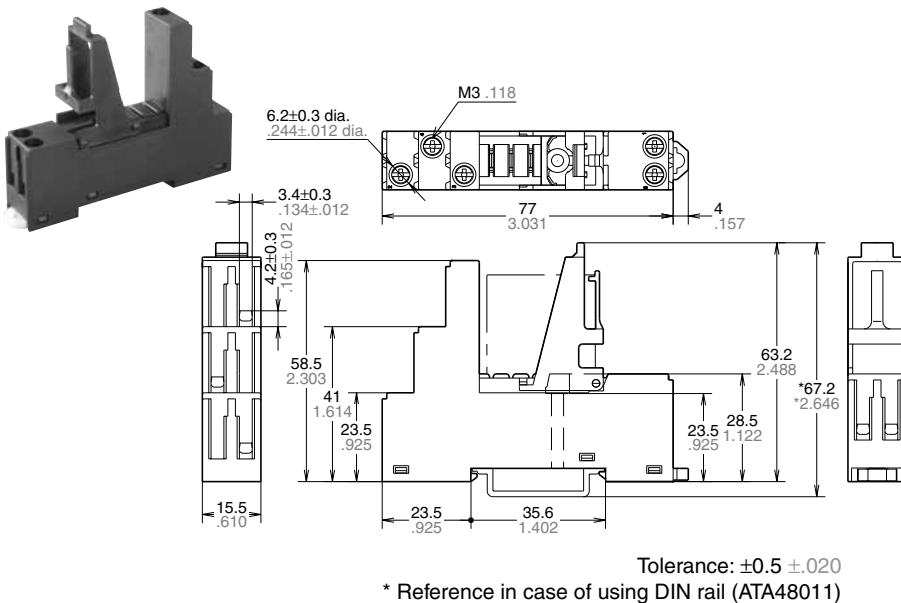

Note: Use rod or plate terminals, etc. (You cannot use Y-shape or round terminals.)

# HN (AHN1, 2, 3)

## 6. HN2 Screw terminal socket

mm inch

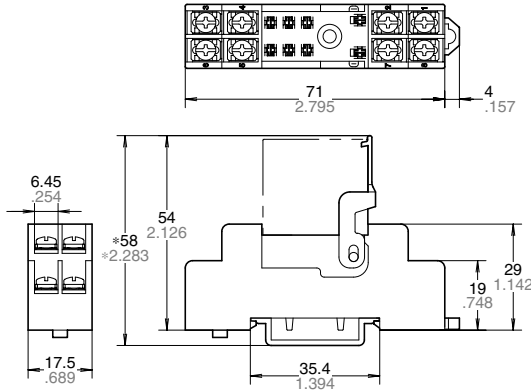

Schematic (Top view)

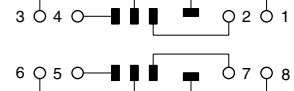

Mounting hole dimensions

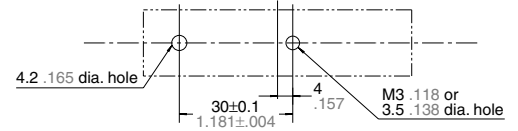

Tolerance:  $\pm 0.5 \pm 0.020$

\* Reference in case of using DIN rail (ATA48011)

## 7. HN2 Screw terminal socket (Finger protect type)

mm inch

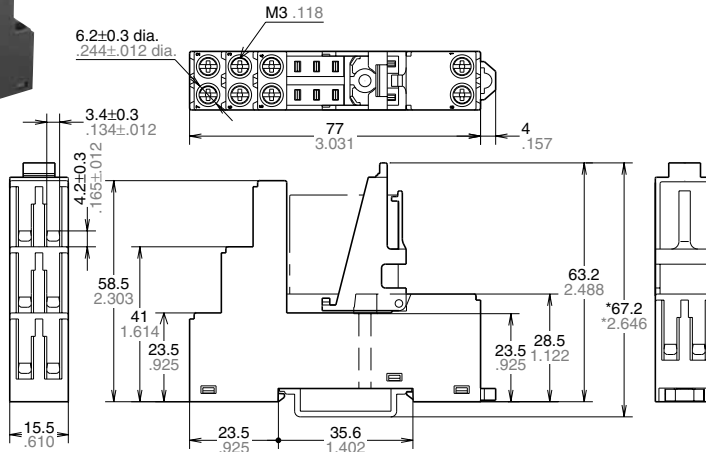
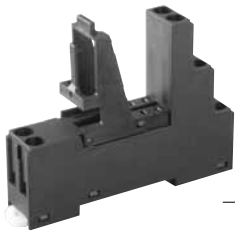

Schematic (Top view)

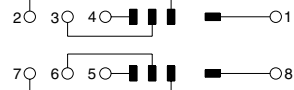

Mounting hole dimensions

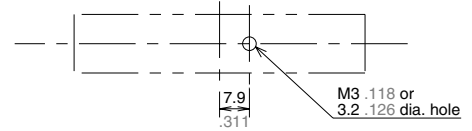

Tolerance:  $\pm 0.5 \pm 0.020$

\* Reference in case of using DIN rail (ATA48011)

Note: Use rod or plate terminals, etc. (You cannot use Y-shape or round terminals.)

## 8. HN1 PC board terminal socket

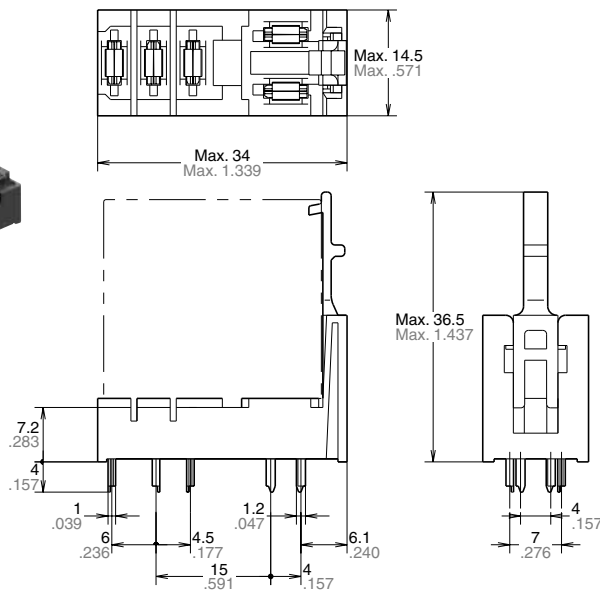

PC board pattern (Bottom view)

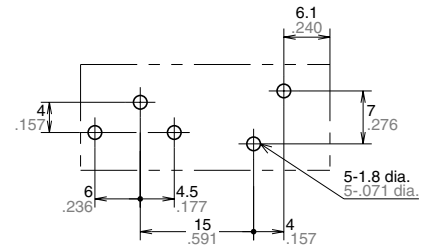

Tolerance:  $\pm 0.1 \pm 0.004$

Dimension :	Tolerance
Max. 1mm .039 inch:	$\pm 0.1 \pm 0.004$
1 to 3mm .039 to .118 inch:	$\pm 0.2 \pm 0.008$
Min. 3mm .118 inch:	$\pm 0.3 \pm 0.012$

## 9. HN2 PC board terminal socket

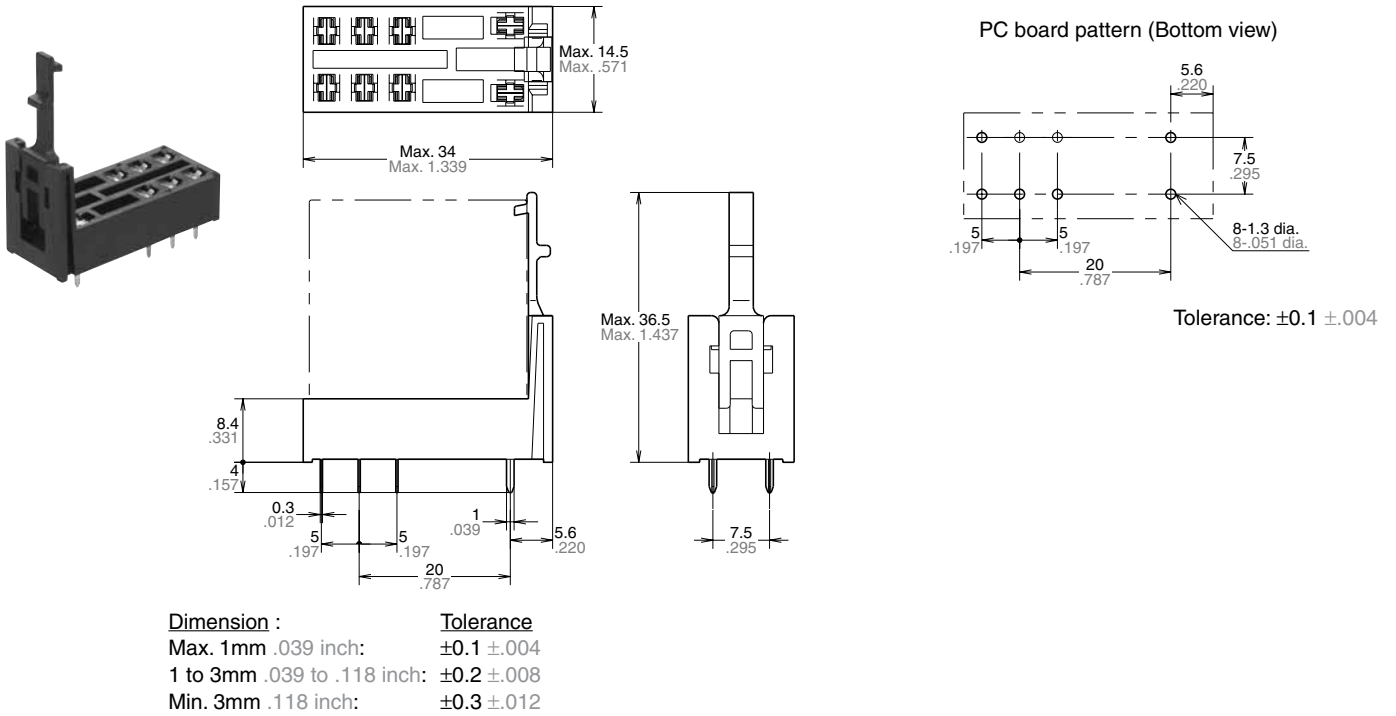

## REFERENCE DATA

1-(1). Max. switching capacity (1 Form C and 1 Form A)

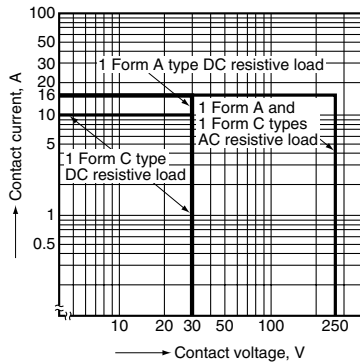

1-(2). Max. switching capacity (2 Form C)

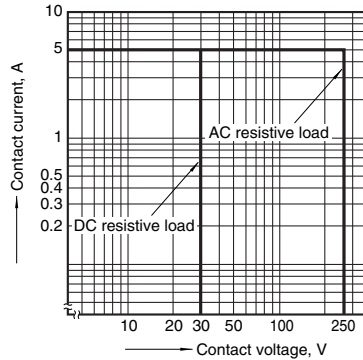

2-(1). Coil temperature rise (1 Form C/AC and 1 Form A/AC types)

Measured portion: Inside the coil  
 Ambient temperature: 70°C 158°F

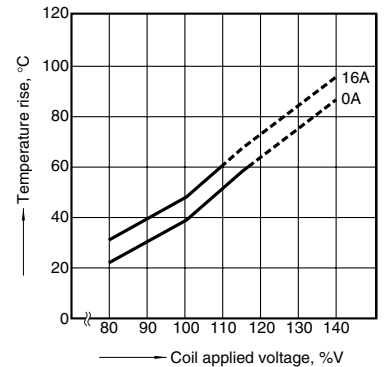

2-(2). Coil temperature rise (1 Form C/DC and 1 Form A/DC types)

Measured portion: Inside the coil  
 Ambient temperature: 70°C 158°F

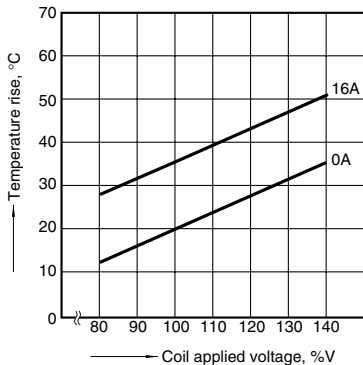

2-(3). Coil temperature rise (2 Form C/AC type)

Measured portion: Inside the coil  
 Ambient temperature: 70°C 158°F

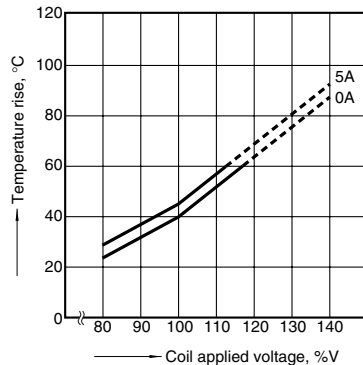

2-(4). Coil temperature rise (2 Form C/DC type)

Measured portion: Inside the coil  
 Ambient temperature: 70°C 158°F

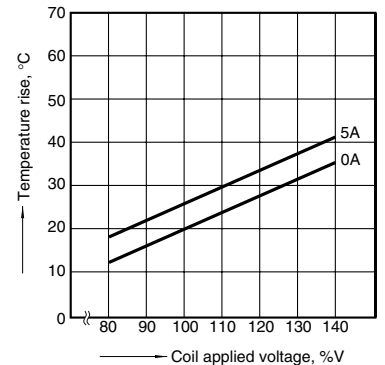

# HN (AHN1, 2, 3)

## NOTES

### 1. Coil operating power

To ensure proper operation, the voltage applied to both terminals of the coil should be  $\pm 5\%$  (at  $20^{\circ}\text{C}$   $68^{\circ}\text{F}$ ) the rated operating voltage of the coil.

Also, be aware that the pick-up and drop-out voltages will fluctuate depending on the ambient temperature and operating conditions.

### 2. LED indications

The light of the light emitting diode is what displays operation. If voltage remains after relay dropout, the LED might illuminate briefly.

### 3. Switching lifetime

The switching lifetime is defined under the standard test condition specified in the JIS C 5442(\*2) standard (temperature  $15$  to  $35^{\circ}\text{C}$   $59$  to  $95^{\circ}\text{F}$ , humidity  $25$  to  $75\%$  R.H.). Check this with the real device as it is affected by coil driving circuit, load type, activation frequency, activation phase, ambient conditions and other factors.

Also, be especially careful of loads such as those listed below.

1) When used for AC load-operating and the operating phase is synchronous. Rocking and fusing can easily occur due to contact shifting.

2) High-frequency load-operating  
When high-frequency opening and closing of the relay is performed with a load that causes arcs at the contacts, nitrogen and oxygen in the air is fused by the arc energy and  $\text{HNO}_3$  is formed. This can corrode metal materials.

Three countermeasures for these are listed here.

(1) Incorporate an arc-extinguishing circuit.

(2) Lower the operating frequency

(3) Lower the ambient humidity

### 4. Direct mount type (TM type)

If the current to the connection terminal will exceed  $10\text{ A}$ , we recommend connecting with solder. If you are going to use a tab terminal when the current will exceed  $10\text{ A}$ , make sure to verify the temperature rise on the receptacle side under actual conditions before using.

### 5. Conditions for operation, transport and storage

1) Ambient temperature, humidity, and atmospheric pressure during usage, transport, and storage of the relay:

(1) Temperature:

$-40$  to  $+70^{\circ}\text{C}$   $-40$  to  $+158^{\circ}\text{F}$

(2) Humidity:  $5$  to  $85\%$  RH

(Avoid freezing and condensation.)

The humidity range varies with the temperature. Use within the range indicated in the graph below.

Temperature and humidity range for usage, transport, and storage

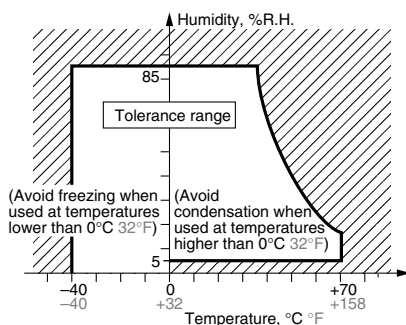

(3) Atmospheric pressure:  $86$  to  $106\text{ kPa}$

2) Condensation

Condensation forms when there is a sudden change in temperature under high temperature and high humidity conditions. Condensation will cause deterioration of the relay insulation.

3) Freezing

Condensation or other moisture may freeze on the relay when the temperatures is lower than  $0^{\circ}\text{C}$   $32^{\circ}\text{F}$ .

This causes problems such as sticking of movable parts or operational time lags.

4) Low temperature, low humidity environments

The plastic becomes brittle if the relay is exposed to a low temperature, low humidity environment for long periods of time.

### 6. About the relay-securing hook

• Screw terminal socket

1) Installation of the securing hook is easily performed by pressing upward in the direction of the arrows.

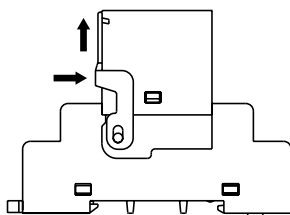

2) Removal of the securing hook is easily performed by releasing the hook and pressing down, as shown in the figure.

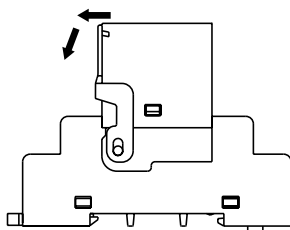

• Screw terminal socket  
(Finger protect type)

1) Install the securing hook by pressing the parts with arrows after inserting the relay.

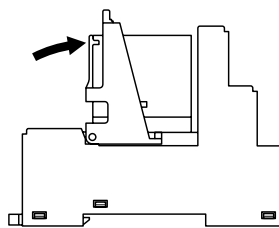

2) Removal of the relay is easily performed by pressing the parts with arrows.

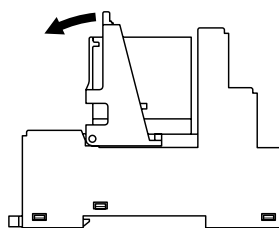

• PC board terminal socket

1) Installation of the securing hook is easily performed by pressing upward in the direction of the arrows.

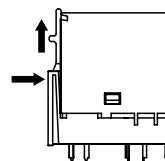

2) Removal of the securing hook is easily performed by releasing the hook and pressing down, as shown in the figure.

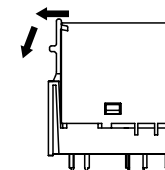

\* To prevent damage and deformity, please use the relay-securing hook at  $10\text{ N}$  or less.

### 7. Diode characteristics

1) Reverse breakdown voltage:

Min.  $1,000\text{V}$  (with diode type)

Min.  $400\text{V}$  (with diode and LED indication type)

### 8. Diode type

Since the diode inside the relay coil are designed to absorb the counter emf, the element may be damaged if a large surge, etc., is applied to the diode.

If there is the possibility of a large surge voltage from the outside, please implement measures to absorb it.

### 9. Installation

If you will be installing adjacent to other relays, please keep a distance of at least  $5\text{ mm}$  from the relay.